

CHARACTERISTICS REVIEW OF BOC MODULATION INCLUDING ITS ACQUISITION & TRACKING SCHEMES

Kriti Kulshrestha, Ritu Kumri, Saloni Garg, Swati Adhikari, Geetanjali Raj

E-Mail Id: kriti.18bec3001@abes.ac.in, ritu.17bec1179@abes.ac.in, saloni.17bec1039@abes.ac.in,

swati.17bec1077@abes.ac.in, geetanjali.raj@abes.ac.in

ABES Engineering College, Ghaziabad, Uttar Pradesh, India

Abstract- The advanced generation of Global Navigation Satellite System (GNSS), Galileo system and GPS system use a modern modulation process named as Binary Offset Carrier (BOC) modulation. BOC signal is the product in time domain of PRN code, a sinusoidal carrier, a subcarrier and a data sequence. This paper presents the general difference between BPSK modulation and BOC modulation. Followed by this, BOC scheme is further explained in detail along with its different variants, Acquisition techniques and Tracking schemes.

Keywords: GNSS, BOC, BPSK, Acquisition techniques and tracking schemes.

1. INTRODUCTION

John Betz came up with a development of 'Binary Offset Carrier (BOC) Modulation' to allow compatibility with the Satellite Navigation System. The key concept behind BOC modulation is to minimize interference in the modulated signal of the Binary Phase Shift Keyed (BPSK), whose spectrum is in the shape of Sinc function. Therefore the BPSK modulated signal mainly concentrate much of its spectral energy, which is surrounded about the frequency of the carrier and both the specified spectral lobes (which are very far from the carrier), and thus the spectrum is named as split spectrum. The main drawback of the BOC modulation technique is the uncertainty of the 'Auto-Correlation Function (ACF)', which brings difficulty in acquisition activity as well as it increases the possibility of false tracking.

The BOC modulated signals in 'Global Navigation Satellite System' (GNSS) can be processed either through a full BOC receiver or via various unambiguous techniques. BOC modulation was firstly introduced in Military Global Positioning systems but with the time it is also now used for civil applications in order to have better navigation and positioning systems. Nowadays we are using BOC modulation in place of BPSK, but still BPSK are in use for different navigation systems. The reasons to choose BOC modulation technique are as follow:-

- BOC modulation receiver efficiency is optimized
- Satellite Signal Loss was small
- Energy efficiency was maximum
- BOC modulation solution has eliminated interference

The paper includes several comparisons between Binary Offset Carrier (BOC) and Binary Phase Shift Keyed (BPSK) modulation, detailed information about BOC Modulation Scheme, different variants of BOC modulation, acquisition approaches and tracking approaches required for the BOC modulation. The document is set out as follows. Section II addresses the context of BOC vs. BPSK based on multi-path performance and discusses the benefits of BOC modulation over BPSK modulation and briefly describes the mechanism of BOC modulation. Section III describes various types of BOC modulation which includes 'Coded BOC modulation', 'Sine and Cosine BOC modulation', and 'Alternative BOC modulation (AltBOC)'. Section IV presents characteristics of autocorrelation function for BOC modulation. Section V presents acquisition techniques. Section VI presents tracking approaches for the BOC modulation.

2. HISTORY

2.1 Comparison of 'BOC and BPSK'

A BOC signal modulates an additional square wave onto a Binary Phase Shift Key (BPSK). BPSK (m) uses a chipping rate of $1.023 \cdot m$ Gigahertz (GHz), and a BOC (n, m) signal requires a BPSK (m) to modulate it with a subcarrier (which is square wave) at a frequency of $1.023 \cdot n$ Gigahertz (GHz). Hence the outcome is that the BOC modulation shifts the main lobe of signal, far from the usual BPSK carrier. As a result we find the signal at the BPSK carrier has a null and thus it does not provide any noteworthy change in the current BPSK. The spread bandwidth of BOC modulated signal also helps to improve multipath performance over BPSK. Also a drawback of interference with BPSK modulated signal was reduced with the help of BOC modulation scheme.

The key application of BOC modulated signal over BPSK signal is that it is capable of allowing the receivers to control Satellite Navigation Systems on multipath. In addition to this, one major benefit of BOC over BPSK is that the BOC modulated signal uses 'BOC' and 'Multiplexed BOC', which come up with efficient multichannel output over the BPSK. The multichannel consequences can also be decreased to a great extent by using "Time Multiplexed BOC (TMBOC)" and "Composite BOC (CBOC)", which is used by "Global Positioning System (GPS)". The

perfect way to have the clear comparison of multipath output between BOC and BPSK signals is by emerging both the signals from the same satellite as discussed in [5] with results.

2.3 Binary Offset Carrier (BOC) Modulation

BOC modulation is the extended version of BPSK and by several analysis as given in [5], it is proved that BOC modulated signals are more superior to the BPSK signals (which are used in Global Positioning System).

BOC signals exhibit the split spectrum property and signal interference declining features. The primary lobes of BOC signals are very far from the middle frequency, which leads to the efficient channel capacity. BOC modulation is the multiplication of a signal by a rectangular sub-carrier whose frequency can be either equal to the chip rate or slightly greater than the chip rate. As a result, the spectrum splits into two portions, thus BOC modulation is further referred as split-spectrum modulation. This feature makes BOC signals as a mixture of two different BPSK signals at $+f_{sc}$ and $-f_{sc}$ (here f_{sc} is the frequency of the subcarrier). The BOC modulation can be described in mathematical terms as:-

$$S_{boc}(t) = q(t) * \text{sign}[\sin(2\pi f_{sc}t)] \dots (1)$$

Here BPSK signal is given as $q(t)$, 'sign' is the Signum Function and f_{sc} is the frequency of Sub Carrier. The above given equation shows the BOC modulated signal. The subcarrier comes up as a null at the middle of the spectrum, which is a very advantageous feature of the BOC modulation technique. BOC modulation is typically applied on "Code Division Multiple Access (CDMA)" signals, where each pseudorandom code chip is distributed into BOC sub-intervals.

3. DIFFERENT VARIANTS OF BOC MODULATION

Several various types of BOC modulation scheme are there, which include: "Cosine BOC", "Sine BOC", "Multiplexed BOC", "Alternative BOC (AltBOC)", "Coded BOC", "Uncoded BOC" etc. Some of them are discussed below.

3.1 Sine and Cosine BOC Modulation

It is shown in [2], that cosine BOC performs well in various aspects like (a) frequency offset from the center of the band, (b) accuracy of code tracking and (c) separation of spectrum, than the sine BOC. The Sine BOC (1, 1) modulation and Manchester code are same (with respect of waveform). The equation for sine modulated BOC signal is represented below-

$$S_{boc}(t) = q(t) * \text{sign}[\sin(2\pi f_{sc}t)] \dots (2)$$

Here BPSK signal is given as $q(t)$ and f_{sc} is frequency of sub carrier. The equation for cosine modulated BOC signal is give as-

$$S_{boc}(t) = q(t) * \text{sign}[\cos(2\pi f_{sc}t)] \dots (3)$$

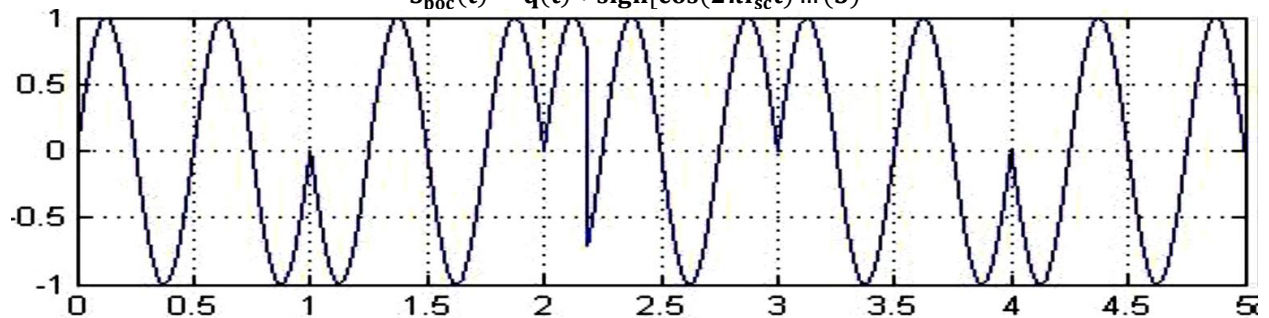

Fig. 3.1 Sine BOC Signal

Fig. 3.1 and Fig. 3.2 are representing the generated functions individually.

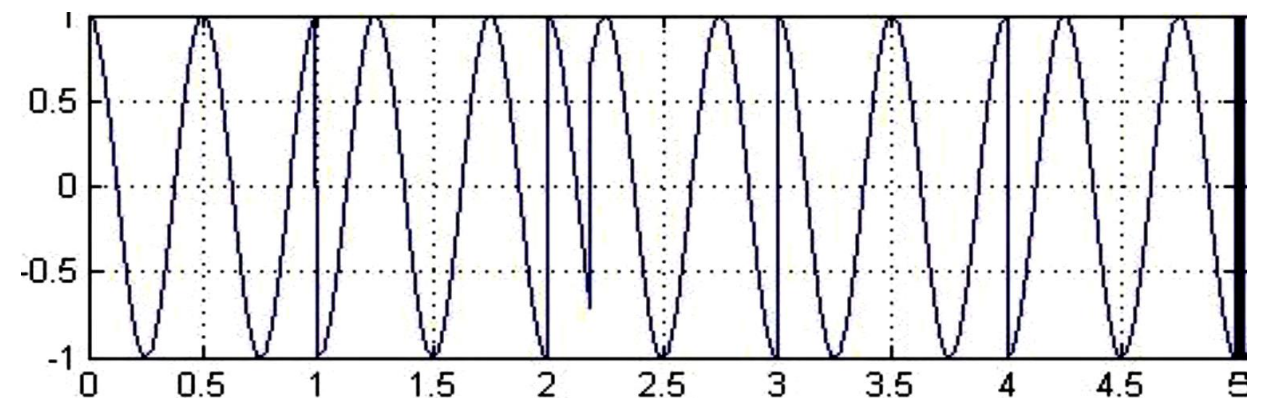

Fig. 3.1 Cosine BOC Signal

The BOC modulated signal's power spectrum is often known as the power that is distributed at any signal frequency. The spectral power density of Sin BOC (f_{sc} , f_c) and Cos BOC (f_{sc} , f_c) signal can be given as [3][4][5][10][11].

$$G_{\sin Boc}(f) = \left[\frac{\sin\left(\frac{\pi f}{f_c}\right) \sin\left(\frac{\pi f}{2f_{sc}}\right)}{\pi f \cos\left(\frac{\pi f}{2f_{sc}}\right)} \right]^2 \dots\dots\dots(4)$$

$$G_{\cos Boc}(f) = f_c \left[\frac{\cos\left(\frac{\pi f}{f_c}\right) \sin^2\left(\frac{\pi f}{4f_{sc}}\right)}{\pi f \cos\left(\frac{\pi f}{2f_{sc}}\right)} \right]^2 \dots\dots\dots(5)$$

BOC signals of various orders are produced and examined by changing the value of f_{sc} and f_c .

With the aid of MATLAB Simulation, the various spectral densities of several orders of BOC signals can be studied.

The various signal spectrums, which are analyzed are given below:

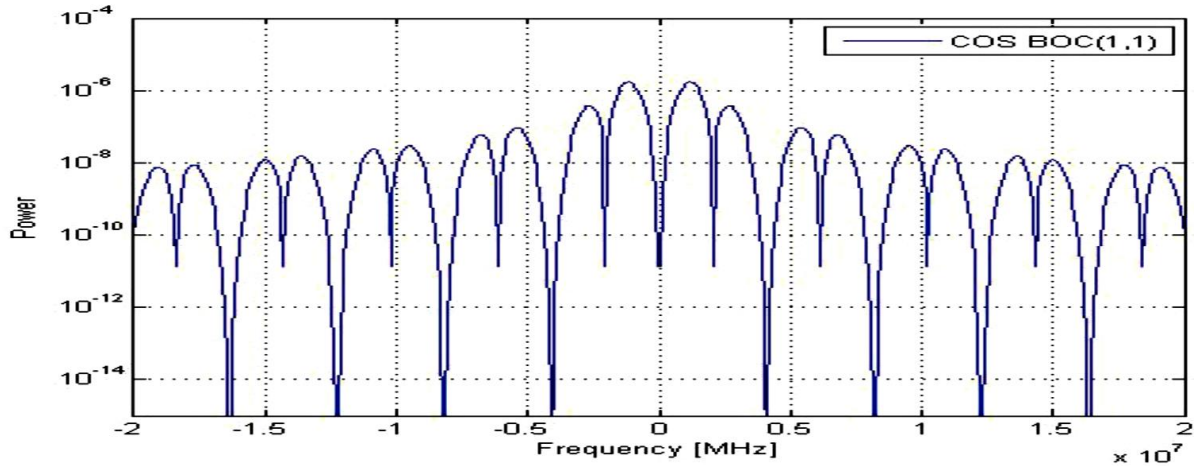

Fig. 3.3 Spectrum of 'BOCcos'

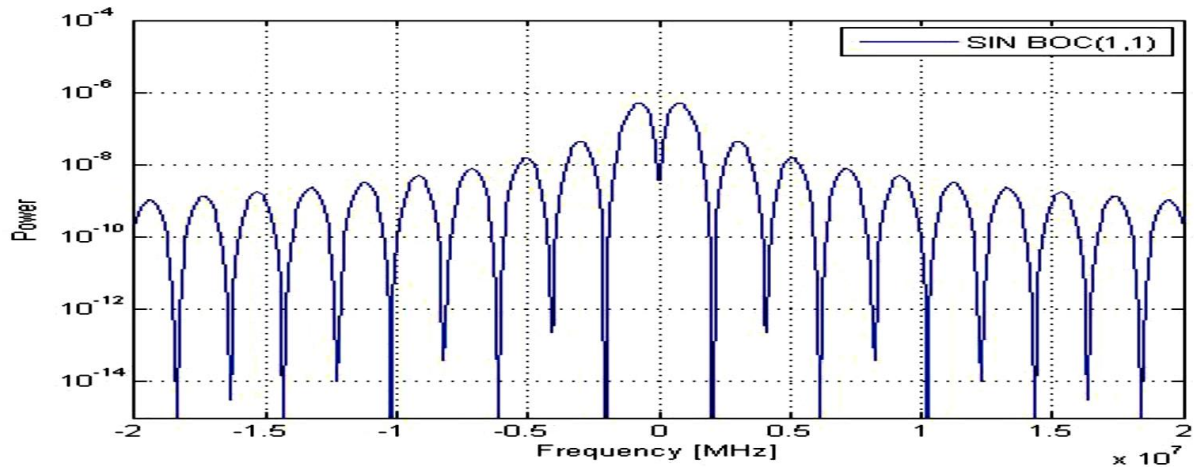

Fig. 3.4 Spectrum of 'BOCsin'

Above Figures display the spectrum of Sine BOC & Cosine BOC subcarrier. From the above figures it is observed that the power content of the lower order BOC signals is higher in primary & secondary lobes of 'Cos BOC' function in comparison to primary & secondary lobes of the 'Sine BOC' function.

3.2 Coded Modulation

By combining error control coding with the aid of BOC scheme, our 'Bit Error Rate' (BER) effect and be refined and reduced. But, when BOC modulation is combined with the coding to achieve the coding gain, there would be an increment in the bandwidth and thus the coded system will need a large channel bandwidth for transmission of signal as compared with the uncoded system. The reason behind this aspect is that, by adding excessive symbols with the information sequence which is transmitted, the noise of the channel will be reduced to a large extent. Thereafter, the coding gain can be obtained even when the bandwidth is expanding.

Therefore, if coding and modulation mechanism are correctly merged and is considered as a single unit then the coding gain will be attained without the expansion in bandwidth. So this mixed process of coding as well as modulation is termed as coded modulation. Therefore achieving coding gain without an increment in the symbol rate (without the expansion in the bandwidth), is not possible with the uncoded technique. Under the impact of 'Additive White Gaussian Noise' (AWGN), a brief comparison is presented between 'Coded BOC' Modulation & 'Uncoded BOC' Modulation in [9].

3.3 Alternative BOC (AltBOC) Modulation

The main difference between AltBOC and BOC modulation is that, BOC modulation does not have independent sideband; AltBOC is an independent solution to the quadrature sideband modulation. However, both AltBOC modulation and BOC modulation are theoretically indistinguishable.

AltBOC come up with four independent carriers which carry four spreading codes along with a complex subcarrier due to which the spectrum does not divide as in case of BOC modulation. But the AltBOC spectrum shifts to lower or higher frequencies as shown in Fig. 3.5.

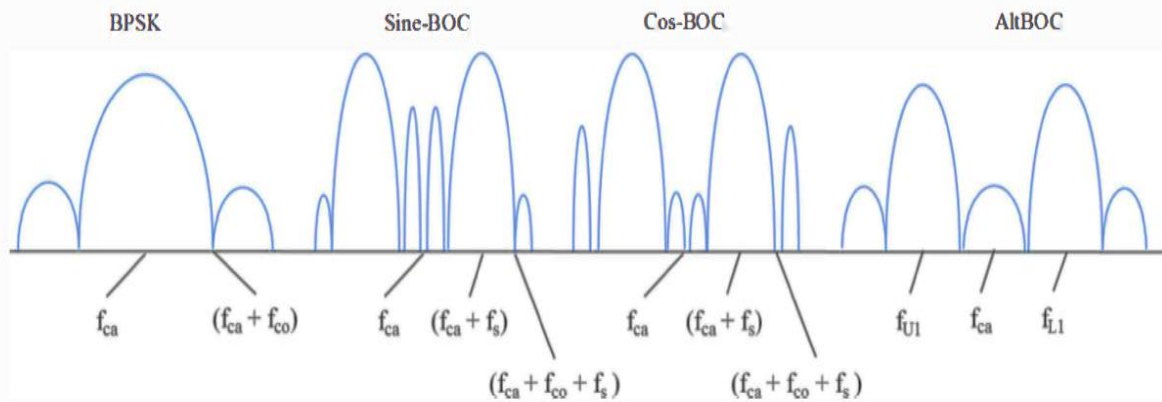

Fig. 3.5 'Power Spectral Density' of BPSK, BOC and AltBOC signals

4. CHARACTERISTICS OF AUTOCORRELATION FUNCTION OF BOC MODULATION

4.1 For BOC Modulation

In BOC modulation, the power spectrum and autocorrelation both depend on the chip rate as well as the features of sub carrier. The ACF of the BOC modulation contains several peaks whose magnitudes are almost equal to the magnitude of central peak. The possibility of false acquisition process or false tracking method will be increased if the side peaks isn't processed in an accurate manner. The characteristics of 'ACF' for BOC Modulation can be represented in Table 4.1.

4.2 For Truncated Pseudo Random Noise (TPRN) Sequence

Here, square sub carrier is used by the BOC signal in order to modulate the sequences 'Pseudo Random Noise' (PRN). By serial connection of shift registers (of linear feedback), whose output is connected from one or more stages, we can generate a PRN sequence. Generally instead of being perfectly random, these sequences have the properties of perfect correlation, which are widely used in the applications such as radar ranging system, error correction and cryptographic systems

Table-4.1 Characteristics of 'ACF' for BOC Modulation

Modulation	Peaks in ACF	Delay Values of peaks (Seconds)	ACF Values for peak at $j/(4mf_{ncm})$
BOCs(m,n)	$\frac{4m}{n} - 1$	$j/(4mf_{ncm})$ $2 - \frac{4m}{n} \leq j \leq -2 + \frac{4m}{n}$	$\frac{(-1)^{j/2}(2m/n - j/2)}{2m/n}$ j even
			$\frac{(-1)^{(j -1)/2}}{4m/n}$ j odd
BOCc(m,n)	$\frac{4m}{n} + 1$	$j/(4mf_{ncm})$ $1 - \frac{4m}{n} \leq j \leq -1 + \frac{4m}{n}$	$\frac{(-1)^{j/2}}{(2m/n - j/2)(2m/n)}$ j even
			$\frac{(-1)^{(j +1)/2}}{4m/n}$ j odd

The BOC signal is obtained by the multiplication of 'PRN sequence' & the 'square sub carrier'. Mathematically it is expressed as:

$$s(t) = q(t) * \text{sign}[\sin(2\pi f_s t) \dots] \quad (6)$$

and

$$q(t) = \sum q_k * p(t - k * T_c) \dots \quad (7)$$

Here, code sequence is given as c_k , f_s is frequency of sub carrier and $p(t)$ is 'Non Return to Zero' (NRZ) code.

According to Figure 6, PRN sequence is represented in first graph, and then this sequence is changed into bipolar format which is shown in second graph. Signum Function is represented in the third graph. Fourth graph shows the multiplication of third graph and the second graph. The study for the properties of ACF is elaborated by simulation using MATLAB as given in [12].



Fig. 4.1 BOC Modulated Waveform

5. ACQUISITION TECHNIQUES OF BOC MODULATION

The 'Over-Sampled' scheme, 'Synthesized Correlation Function' (SCF) scheme, 'Sub Carrier Phase Cancellation' (SCPC) scheme [1][6] & 'BPSK-like' scheme [1] are numerous acquisition schemes. These methods transform the association function from multiple peaks to a single peak, removing complexity and thereby calling these acquisition methods unambiguous. The main peak in case of Over-sampled scheme can be found by comparing different energies. But also we could conceive it in the occurrence of BOC (2,2) for simplicity. This technique is complex and will cause extreme increment in acquisition time [6].

The Synthesized Correlation Function scheme is used to build a correlation function in which the side peaks are suppressed successfully [7].

Different forms of Acquisition schemes which are practically successful in every aspect are SCPC and BPSK-like, which are explained below in brief.

5.1 SCPC Acquisition Scheme

The 'Sub Carrier Phase Cancellation' (SCPC) scheme is used to have an unambiguous acquisition of BOC signal.

This technique generates two correlation channels as shown in Figure 7. Here in first channel, the output received (as well as filtered) is being matched with the in-phase sub carrier (BOC signal). In the second channel, the signal received (as well as filtered) is matched with the quadrature sub carrier (BOC signal). After that both the correlated channels are combined and hence an ACF is obtained which is similar for the BPSK signal.

5.2 "BPSK-like" Acquisition Scheme

"BPSK-like" acquisition scheme uses multicarrier representation of BOC modulation and this multicarrier representation is obtained by the multiplication of sub carrier and carrier which is equal to the addition of the infinite carrier (including the linear change in frequency). The multi-carrier representation is given in Figure 8.

Synchronously, "BPSK-like" method removes both carrier and sub carrier. It filters and weights the sum and takes out the sideband respectively and hence side peaks effects are attenuated. The simplicity in the implementation process and the minimal consequences of the filter makes the greatest advantage of this method.

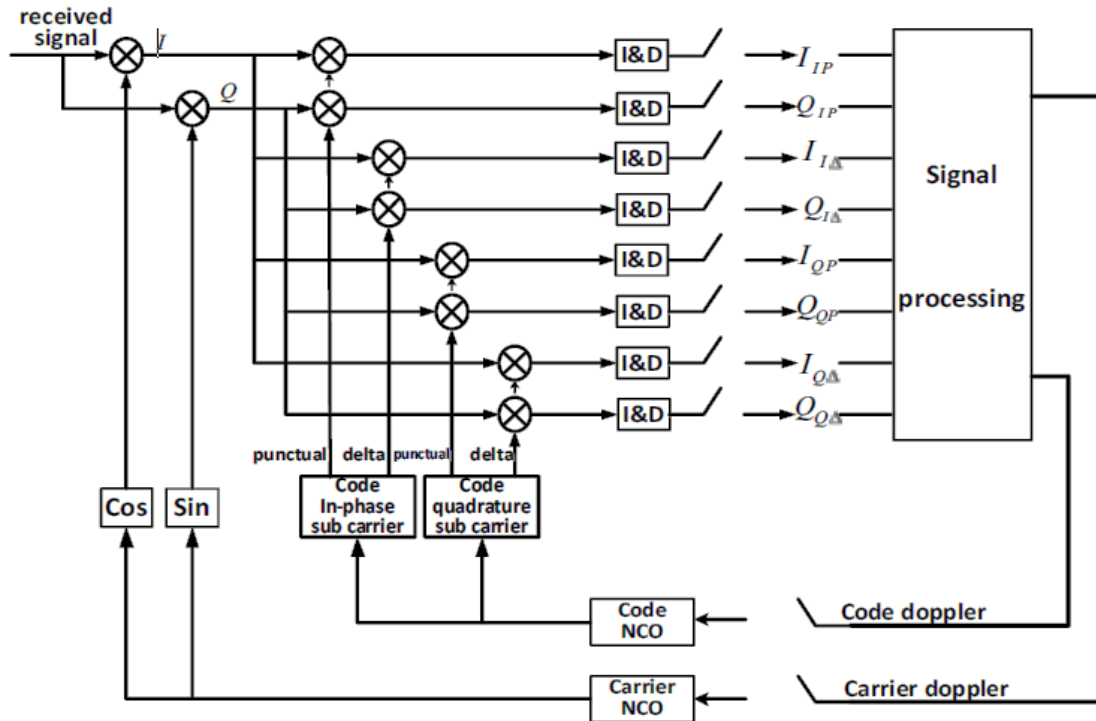

Fig. 5.1 Principle diagram of SCPC

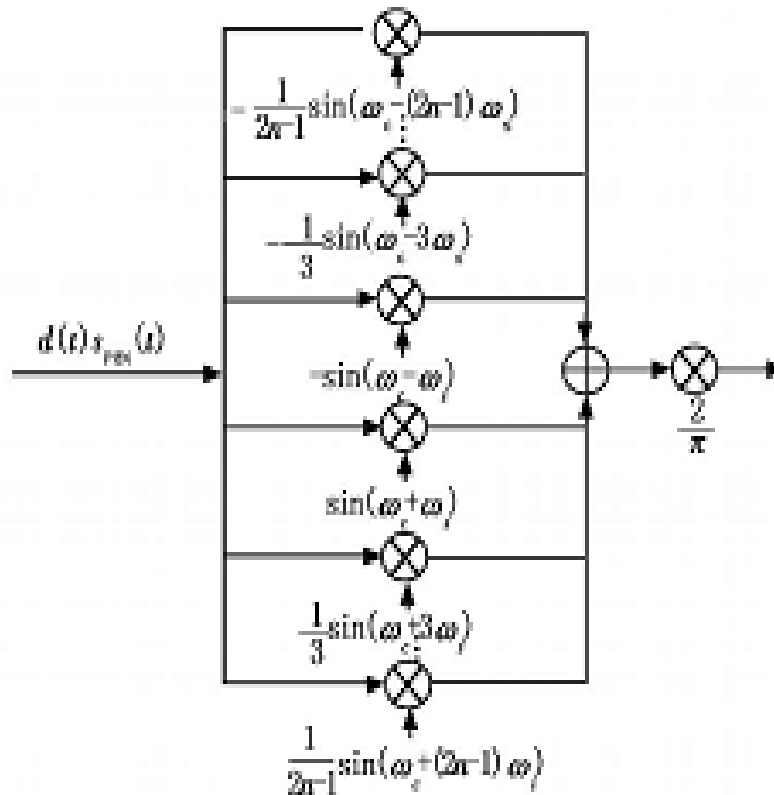

Fig. 5.2 Multi-carrier representation of BOC modulation

6. TRACKING TECHNIQUES OF BOC MODULATION

When the local carrier is supposed to be in-phase with the receiver signal then acquisition mechanism pause and thereafter tracking process took place. There are two main types of tracking approaches. First is the “Ambiguous Tracking” with double discriminator or counter and the next is the “Unambiguous Tracking” whose building root is dependent on single peak structure of recreated correlation function.

6.1 Ambiguous Tracking Approach

It takes a 'very early / very late' method and an algorithm for hopping. Two variants of discriminators can be introduced in this design which is key help discriminators and counterparts.

The algorithm attains the comparison between the amplitudes by using a 'simple up/down counter' system in the counter mode as well as in "main-assistant discriminator" method. The architecture of 'Code Tracking Loop' scheme is given in Fig. 6.1.

When the output amplitude of the main wizard discriminator is smaller than the limit value, the code step can be changed to represent the polarity of the main wizard discriminatory output.

6.2 Unambiguous Tracking Approach

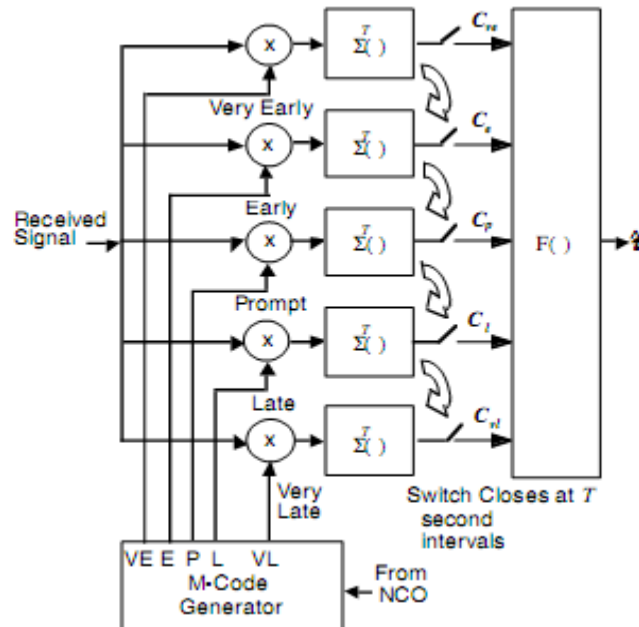

Fig. 6.1 Architecture for "Code Tracking Loop" used for 'very-early & very-late' scheme

The side peaks of redesigned correlation function are removed mostly, so the "Unambiguous Tracking Approach" executes the normalized discriminator by using reconstructed correlation function. By using such discriminator we can maintain the loop gain.

CONCLUSION

The BOC modulation is widely used in the military GNSS. Several acquisition techniques and tracking techniques are covered in this paper. According to different analysis it is observed that by taking perfect correlate spacing, multiplexed BOC (MBOC) modulation gives better results as compared to BOC modulation. In contrast with cosine modulated BOC signals, we have found that sine BOC signals show stronger results because low power is localized in secondary lobes and because they increase in the direction of modulation, "cosine BOC" spectral outputs are much higher than their counterpart. The bit error rate performance of given Coded BOC modulation in AWGN channel is improved and hence it is used in radio navigation systems.

ACF of BOC modulated TRPN was calculated and observed in MATLAB with the aid of software analysis. Therefore the TRPN generated, is the best chosen as well as best possible sequence that retains the randomness.

REFERENCES

- [1] James H. Lindholm "An Analysis of the PseudoRandomness Properties of Subsequences of Long m-Sequences", IEEE Trans Inf. Theory, vol.IT-14, no. 4, July, 1968.
- [2] S. Wainberg and J. K. Wolf, "Subsequences of pseudorandom sequences", IEEE Trans. Commun. Technol., vol. COM-18, no. 5, pp. 606-612, Oct. 1970.
- [3] S. W. Golomb, "Shift Register Sequences", Laguna Hills, CA: Aegean Park Press, 1981.
- [4] R. N. Mutagi, "PseudoNoiseSequences for Engineers", Electronics and communication engineering journal APRIL1996.
- [5] J. W. Betz, "An Offset Carrier Military Signal for Spectrum Sharing", MITRE Presentation to the GPS JPO, 21 August, 1997.
- [6] Fine, P., and Wilson, W. "Tracking algorithm for GPS offset carrier signals", Proceedings of U.S. Institute of Navigation NTM Conference, San Diego, CA, 671—676, 1999.

- [7] Betz, J. W. “Binary offset carrier modulations for radio navigation”, Navigation, Journal of the Institute of Navigation, 227—246, 2002.
- [8] G. W. Hein, J. Godet, J. L. Issler, J. C. Martin, R. Lucas-Rodriguez, and T. Pratt, “The Galileo frequency structure and signal design,” Proc. ION, pp. 1273–1282, 2002.
- [9] Martin, N., Leblond, V., Guillotel, G., and Heiries, V. “BOC(x,y) signal acquisition techniques and performances”, Proceedings of U.S. Institute of Navigation GPS/GNSS Conference, Portland, OR, , 188—198, 2003.
- [10] N. Martin, V. Leblond, G. Gilles and V. Heiries, “BOC (x,y) signal acquisition techniques and performances”, Proc of ION GPS/GNSS2003, pp. 188-198 , 2003.
- [11] O. Julien, M.E. Cannon, and G. Iachapelle, “A New Unambiguous BOC(n,n) Signal Tracking Technique”, Europe navigation Conference GNSS, Netherlands: EUGIN, DGON, 2004.
- [12] V. Heiries, 'Signal Acquisition Efficiency Non-Ambiguous Study' ION GNSS, pp.2611-2622. 2004-2004
- [13] Heiries, V., Roviras, D., Ries, L., and Calmettes, V. “Analysis of non-ambiguous BOC signal acquisition performance”, Proceedings of U.S. Institute of Navigation GNSS Conference, Long Beach, CA, 2004.
- [14] Ward “P. A design technique to remove the correlation ambiguity in binary offset carrier (BOC) spread spectrum signals (revised version)”, U.S. Institute of Navigation NTM Conference, San Diego, CA, 886—896, 2004.
- [15] A. Burian, “BPSK-like methods for hybrid-search acquisition of Galileo signals”, IEEE ICC 2006 Proceedings, 2006.
- [16] Avellone G, Frazzetto M, Messina E. “The Acquisition Ambiguity for Galileo BOC(m,n) modulated signals”, IEEE International Conference, ICC '07 Communications. Glasgow: IEEE, . 4438– 4443, 2007.
- [17] Floc’H, JJ. and Matthias Soellner “Comparison Between BOC CBOC and TMBOC Tracking”, ION NTM 2007, 22-24, San Diego, CA, January 2007.
- [18] Avellone G, Frazzetto M, Messina E. “The Acquisition Ambiguity for Galileo BOC(m,n) modulated signals”, IEEE International Conference, ICC '07 Communications. Glasgow: IEEE, 4438– 4443, 2007.
- [19] L. Lestarquit, G. Artaud, and J. L. Issler, “AltBOC for dummies or everything you always wanted to know about AltBOC”, Proc. IONGNSS 2008, pp. 961-970, Sep. 2008.
- [20] AbhijitMitra, “Properties of Pseudo Noise Sequences with a Simple Proposal of Randomness Test”, International Journal of Electrical and Computer Engineering 3:3 2008.
- [21] N. C. Shivaramaiah, and A. G. Dempster, “The Galileo E5 AltBOC: understanding the signal structure”, Proc. IGNSS Symposium, Dec. 2009.
- [22] P.Banerjee, UshabenKeshwala and Monica Kaushik“Study on Potentiality of Truncated PRN Sequences for Communication”, CODIS 2012, JU, Kolkata, IEEE Xplore, pp.409-412, Dec 28-29, 2012.
- [23] B.Tripathi, R.Tulsian and R.C. Jain “Performance comparison of sine and cosine phased BOC signals used for radio navigation”, Froc. IFACEGNCA, Feb 2012.
- [24] P.Banerjee, UshabenKeshwala and Monica Kaushik “Study on Potentiality of Truncated PRN Sequences for Communication”, CODIS 2012, JU, Kolkata, IEEE Xplore, pp.409-412, Dec 28-29, 2012.
- [25] B.Tripathi, R.Tulsian and R.C. Jain “Performance comparison of sine and cosine phased BOC signals used for radio navigation”, Froc. IFACEGNCA, Feb 2012.
- [26] Swati Rathore, Ankita Pramanik, S. J. Krishna Prasad, “Binary offset carrier modulation for wireless radio communication”, International Conference on Electronics and Communication Engineering, Bengaluru, pp-154-157, 28th April-2013.